

# *SmartDrive MX1+*

Wheelchair Power Assist

## User's Manual

**max mobility,<sup>®</sup> llc**

5425 crossings boulevard  
nashville, tn 37013 usa  
p: 800.637.2980  
f: 888.411.9027  
[www.max-mobility.com](http://www.max-mobility.com)





## Specification Sheet

Manufacturer: Max Mobility, LLC  
 Address: 5425 Crossings Blvd.  
 Nashville, TN 37013  
 USA



## SmartDrive MX1+ Wheelchair Power Assist

Range:	10 miles
Maximum speed (level surface):	5.5 mph
Maximum speed (6° incline):	5.0 mph
Motor power:	250 W
Motor voltage:	24 V
Operating temperature:	-25 °C to 50 °C
Continuous theoretical driving range:	11.7 W-h/km
Maneuvering theoretical range:	18.6 W-h/km
Maximum thermal drive test range:	60 minutes / 1522 ft (no failure)
Total weight:	19.8 lbs

*NOTE: The stated values are from testing with a 250 lb. occupant. The range, speed, etc. vary depending on driving conditions.*

### Drive Unit Model: SD1.0

Overall length:	14.3 in
Overall width:	5.5 in
Overall height:	9.5 in
Weight:	11 lbs
Omni-wheel diameter:	7.6 in
Omni-wheel width:	2.8 in

### Battery Unit Model: SB1.0

Battery type:	Lithium-Ion (Lithium Iron Phosphate)
Nominal operating voltage:	24 V
Electric charge:	10 A-h
Overall length:	14.9 in
Overall width:	6.7 in
Overall height:	2.4 in
Weight:	8.3 lbs

### Wheelchair Compatibility

Drive wheel diameter:	22, 24, 25 or 26 in
Minimum seat width:	10 in
Minimum seat depth:	12 in
Maximum seat depth:	20 in
User weight:	80 - 250 lbs

The SmartDrive has been tested and conforms to all applicable requirements of *ANSI/RESNA Standards for Wheelchairs - Volume 1 and Volume 2*.

\*\*A wheelchair's specifications provided by its manufacturer may be slightly affected by the addition of the SmartDrive.\*\*



# Table of Contents

	<b>Specification Sheet</b>	<b>I</b>
	<b>Table of Contents</b>	<b>II</b>
<b>1.</b>	<b>Introduction</b>	<b>1</b>
	Intended Use of the SmartDrive . . . . .	1
	Must Read Prior-to-Use Information . . . . .	1
	Warnings and Safety Precautions . . . . .	1
	Electromagnetic Interference (EMI) . . . . .	3
	List of Components . . . . .	3
<b>2.</b>	<b>SmartDrive Set-Up</b>	<b>5</b>
	Adaptive Clamp Mounting . . . . .	5
	Button Mounting . . . . .	6
	Drive Unit Attachment and Removal . . . . .	7
	Battery Unit Clipping . . . . .	8
<b>3.</b>	<b>Operating the SmartDrive</b>	<b>10</b>
	Power-Assist ON/OFF . . . . .	10
	Switching Between States . . . . .	10
	Power-Assist State . . . . .	10
	Indoor Mode . . . . .	10
	Braking . . . . .	11
	Outdoor Mode . . . . .	11
	Operating Conditions . . . . .	12
<b>4.</b>	<b>Battery</b>	<b>12</b>
<b>5.</b>	<b>Maintenance</b>	<b>13</b>
	Cleaning . . . . .	13
	Roller Lubricating and Replacement . . . . .	13
	Other Maintenance . . . . .	13
<b>6.</b>	<b>Warranty</b>	<b>13</b>
	Manufacturer's Contact Information . . . . .	13
<b>7.</b>	<b>EC Authorized Representative</b>	<b>13</b>

# 1. Introduction

## Intended Use of the SmartDrive

The Max Mobility SmartDrive Wheelchair Power Assist device is exclusively intended to provide power assist to manual wheelchairs, empowering disabled persons, including pediatrics, capable of operating a powered and manual wheelchair by providing a means of enhanced mobility. It is also strongly recommended that it be used on manual wheelchairs that meet the "Wheelchair Compatibility" dimensions outlined in the **Specification Sheet** on Page I of this manual.

## Must Read Prior-to-Use Information

Improper use of the SmartDrive or the wheelchair it is attached, depending on surface, weather, and traffic conditions, can present a potential of injury and cause damage to the wheelchair or SmartDrive. Therefore, the SmartDrive must only be handled and used under the following prerequisites:

- The user is both physically and mentally capable of operating the wheelchair and device in all possible conditions and situations.
- Proper instruction on its handling and operation has been received by reading and understanding this user's manual in its entirety.
- No technical modifications have been made to the device.
- The user must take time to become accustomed to the SmartDrive's response and performance by first practicing its operation in a safe area that is free from hazards. One should become familiar with the push recognition, braking response, acceleration/top speed, etc. of the device before venturing out with the device, where potentially hazardous situations may exist. It is strongly recommended that the user not attempt to use the SmartDrive outdoors until it can be safely operated indoors without difficulty.

If any issues or malfunctions exist, cease the use of the SmartDrive and contact Max Mobility for service/further instruction. Any contrary use to the directions of this user's manual, to the recommendations of one's mobility equipment dealer, or to the technical limitations defined by either Max Mobility and one's wheelchair manufacturer is considered to be misuse of the SmartDrive. Max Mobility is not responsible for any injuries or damage caused by this type of misuse.

## Warnings and Safety Precautions



**All warnings and safety precautions issued by one's wheelchair manufacturer must be heeded in addition to those stated in this manual. Failure to do so could result in serious injury or death.**



**Handling or use of the SmartDrive by anyone who has not received proper instruction from this manual may result in serious injury or death.**

**The SmartDrive is for single person use only. Do not use or operate on a wheelchair that is being pushed by an attendant.**

**One MUST familiarize themselves with the response and performance of the SmartDrive prior to regular use. Do not attempt to use outdoors until it can be safely operated indoors without colliding into walls or any other objects.**

**The addition of the SmartDrive to one's wheelchair may cause it to feel different. Take the time to become accustomed to this new feeling.**



**Methods for safe use of a SmartDrive attached wheelchair are different for each user depending on function and ability.**

**The specifications provided by one's wheelchair manufacturer may be slightly affected by the addition of the SmartDrive.**

**Do not take a SmartDrive attached wheelchair on an escalator or moving walkway. Serious bodily injury may occur.**

**Do not lean over the top of the back upholstery to reach objects from behind as this may cause the wheelchair to tip over.**

**The center of balance of a wheelchair may be affected by the attachment of a SmartDrive.**



(Continued on next page)



 Do not shift your weight or sitting position toward the direction you are reaching as one's wheelchair may tip over backwards or sideways.

Do not tip or wheel your wheelchair without assistance, unless you are highly skilled.

Using Anti-Tippers substantially reduces your risk of falling over backwards, which can cause serious injury. If you are afraid of tipping over, use Anti-Tippers. Anti-Tippers will keep you from falling over, but they will limit your ability to be pulled up curbs and some other maneuvers. Just as children learn to ride bikes without training wheels, you may be able to learn to use your wheelchair with Anti-tippers. It is **STRONGLY** recommended that Anti-Tippers be employed to the wheelchair until the user has become accustomed to operating the SmartDrive in all possible environments, situations, and conditions.

Do not attempt to stop a moving wheelchair with wheel locks. Wheel locks are not brakes.

Do not stand on the frame of your wheelchair.

Your wheelchair is not designed for weight training and is unsafe from use as a seat while weight training. Weight training from your wheelchair substantially changes the stability of your chair and may cause tipping.

Make sure the battery unit is charged before use.

Always turn the unit off when parked to prevent accidental activation.

The SmartDrive is not designed to be driven in heavy rain/snow or on wet/icy surfaces which may cause malfunction or damage. Do not use in these conditions or on these surfaces.

Do not operate over rough terrain, slick surfaces, extreme slopes, or loose ground. This may cause injury or damage to your SmartDrive and void the warranty.

Use extreme caution when operating a SmartDrive attached wheelchair in confined areas. Consider powering off the unit to reduce the chance of damage or injury.

 Use extreme caution when operating a SmartDrive attached wheelchair when near streets. Consider

powering off the unit to reduce the chance of accident or injury.



Outdoor Mode operation of the SmartDrive is not intended to be used indoors. Use caution when using this mode of operation, especially indoors.

As for driving up and down slopes, please adhere to the instructions and specifications given by the diverse wheelchair manufacturers.

Riding over curbs or obstacles can cause tipping and serious bodily harm. Turn off your SmartDrive when attempting to ride in these situations. If you have any doubt that you can safely cross any curb or obstacle, **ALWAYS** ask for help. Be aware of your riding skills and personal limitations. Develop new skills only with the help of a companion.

When crossing major roads, intersection, railway crossings or highways as well as when you drive steep, long slopes you should always consider having somebody accompany you in the interest of your safety.

Always use caution when transferring in or out of the wheelchair. Every precaution should be taken to reduce the transfer distance and be certain the wheel locks are engaged to prevent the wheels from moving. Also always power off and consider detaching the SmartDrive drive unit when transferring to and from your chair.

The SmartDrive is not designed to drive up or down large curbs/steps. Only perform this maneuver when absolutely necessary and always ask for help. Also, be sure to turn off your SmartDrive.

The SmartDrive is designed to be used with a seat cushion. It is strongly recommended that a seat cushion be used on your wheelchair when using the SmartDrive.

Do not attempt to attach the SmartDrive to a wheelchair that does not meet the dimensions outlined in "Wheelchair Compatibility" section of the Specification Sheet on Page I of this manual.

Any modifications to the SmartDrive will void the warranty and may create a safety hazard.



*NOTE: Figures and diagrams of the SmartDrive in this manual may vary slightly from your device.*

## Electromagnetic Interference (EMI)

Electromagnetic Interference comes from radio wave sources. Examples of these sources are radio/TV station transmitters, receivers, transceivers [send and receive signals], cell phones, walkie-talkies, etc. There are many sources of EMI in one's daily environment, some that are avoidable and some that one might not even realize. Powered electronic devices, such as the SmartDrive are susceptible to EMI, both strong and weak, from these types of transmitters, as well as from electrostatic discharges (ESD) and conducted sources. These interferences can cause unintentional activation of the SmartDrive motor or damage to its control system, potentially causing a safety hazard and leading to costly repairs.

Every power wheelchair or power assist device can resist EMI up to a certain level, also known as its "immunity level". The higher the immunity level, the less the device is at risk of interference. An immunity level of 20 V/m is understood to provide sufficient protection from the sources encountered on a daily basis. The SmartDrive has been tested and found to be immune to this minimum immunity level of 20 V/m.

Though equipped to be sufficiently protected against EMI, any chair modifications or accessory additions can effect its immunity. Parts from other suppliers have unknown EMI properties, and their interaction with the SmartDrive is untested.

Electromagnetic energy becomes increasing more intense the closer to the source you become. Therefore, it is recommended that the SmartDrive not be operated in close vicinity to sources of radio waves. There are three categories that EMI sources fall under:

1. **Long Range Transceivers:** These are sources of strong radio waves, including commercial radio and TV broadcast antenna towers and amateur (ham) radios.
2. **Medium Range Mobile Transceivers:** These are sources of potentially strong radio waves, including two-way radios used by emergency vehicles, tractor-trailers, and taxis.
3. **Handheld Transceivers:** These are sources of relatively low strength waves but have the possibility of getting very close to your wheelchair, including walkie-talkies, citizen band (CB) radios, cell phones, and other personal communication devices.

The following are not likely to cause EMI problems: Cordless phones, MP3/CD players, TV sets, and AM/FM radios.

If any unintentional activation of the SmartDrive occurs, turn off the unit as soon as it is safe to do so and report the incident to Max Mobility [please indicate any source of EMI that was in close proximity when the incident occurred].

## USA / Canada

This device complies with Part 15 of the FCC rules. Operation is subject to the following two conditions: (1) This device may not cause harmful interference, and (2) this device must accept any interference, including interference that may cause undesired operation. Any changes or modifications not expressly approved by the party responsible for compliance could void the user's authority to operate the equipment.

## List of Components

*(refer to the next page for diagrams)*

- |                   |                           |                         |
|-------------------|---------------------------|-------------------------|
| 1. Battery Unit   | 7. Drive Unit Handle      | 13. Battery Unit Handle |
| 2. Buttons        | 8. Drive Unit LED         | 14. Button Jack         |
| 3. Button Plug    | 9. Battery Unit Connector | 15. Connector Holder    |
| 4. Adaptive Clamp | 10. Cord                  | 16. Button LED          |
| 5. Drive Unit     | 11. Battery Unit Clip     | 17. Button Velcro Loop  |
| 6. Roller         | 12. Omni-Drive Wheel      |                         |



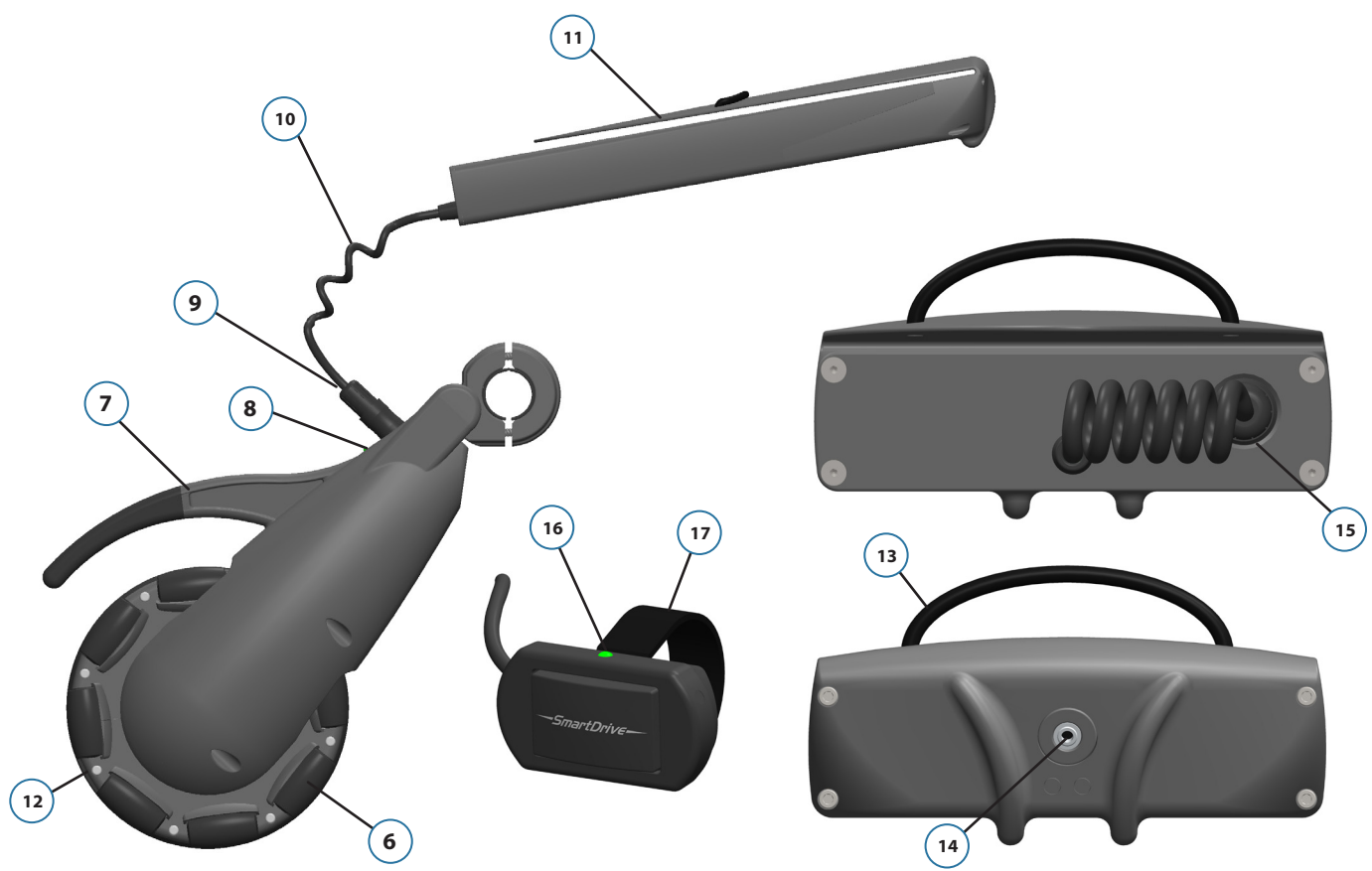
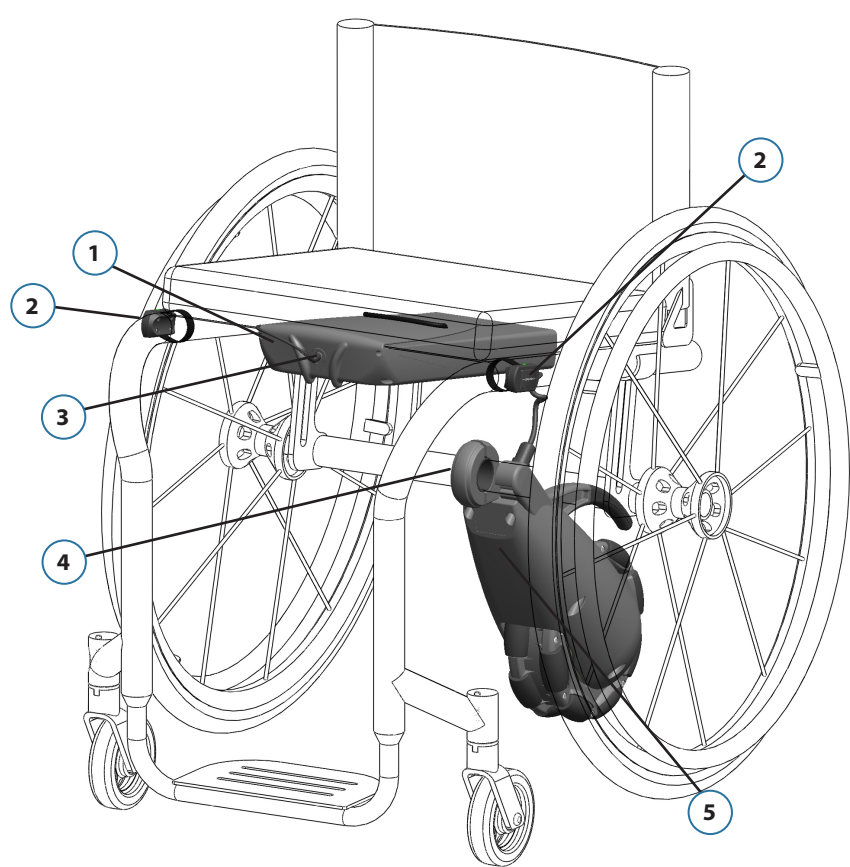



## 2. SmartDrive Set-Up

*NOTE: Refer to the separate directions provided for a folding frame wheelchair and skip to step 4 of the "Battery Unit Clipping" section.*

### Adaptive Clamp Mounting

The SmartDrive adaptive clamp is designed to permanently mount to the axle tube of a wheelchair while presenting a simple means of attaching/removing the drive unit. Slide the provided hard rubber inserts over the axle receiving tube to accommodate smaller tube diameters (see chart below for insert sizing). Use a 5 mm allen wrench to tighten the (2) screws to mount the clamp to the axle receiving tube. The position and orientation outlined below are *critical* to the proper function of SmartDrive and must be heeded. **Save any provided spare clamps as this part may break in extreme loading conditions.**

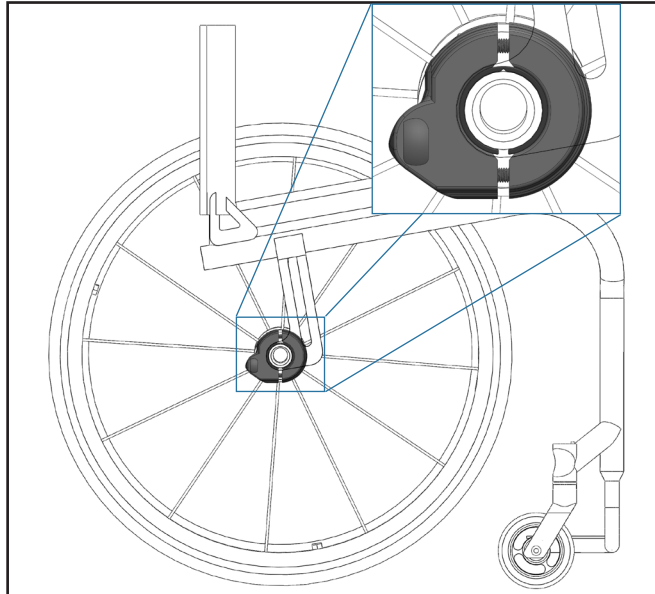

Dots (or numbers) on the side of the rubber inserts are used to identify the tube size they fit:

No Inserts	36 mm
No Dots	1.35" or 35 mm
•	1.25" or 32 mm
••	1.125" or 30 mm
•••	1.0" or 25 mm

1. Make sure the "MAX" on the front of the clamp is right-side up. The protrusions coming from the side of the clamp are to be positioned rearward with the extrusion flats perpendicular to the ground when the chair [with the user in it] is resting on a level plane.

*CAUTION: The front and back of the clamp will not mate even when the screws are sufficiently tight. As shown in the graphic to the left, there should be a gap between the two parts. Over-tightening of the screws [more than 4 ft-lbs] could cause the parts to break during installation.*

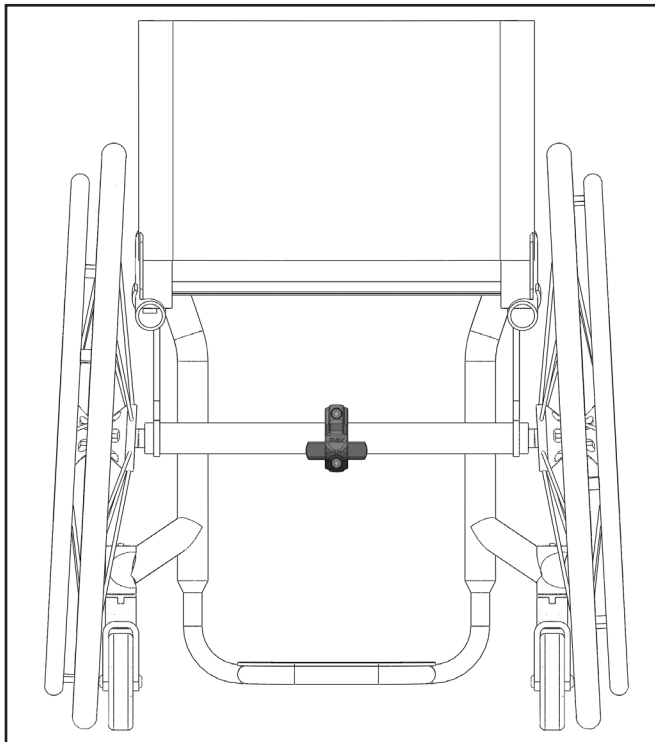

2. The clamp must be positioned midway between the two rear wheels of the wheelchair on the axle receiving tube. The two (2) screws should be tightened to 4 ft-lbs, fixing it in this position and orientation. Failure to do this could cause the wheelchair to not drive/ride straight and/or the clamp to move during use causing the SmartDrive to not function properly.



Adjustments made to the wheelchair set-up could affect the orientation of the SmartDrive clamp. Adjust the clamp whenever changes are made to the chair.

## Button Mounting

The two (2) SmartDrive buttons are easily mounted to each side of the frame of the wheelchair to allow for easy pressing without having to remove your hands from the handrims.

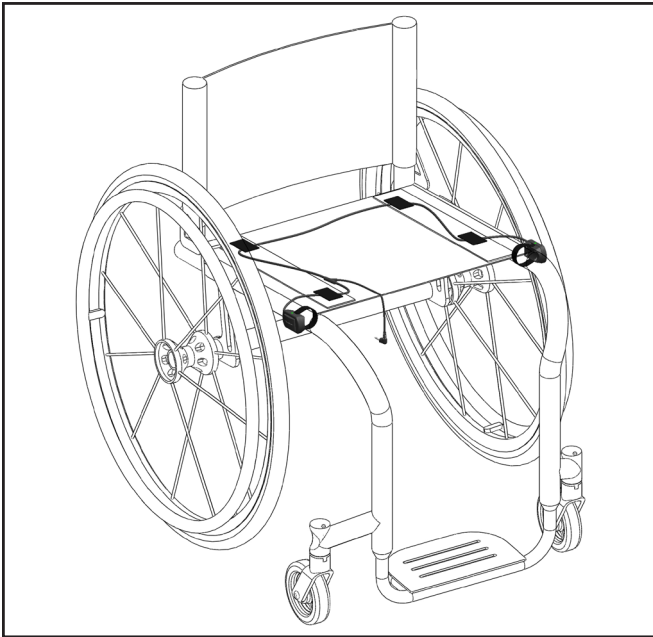

1. Wrap the velcro loop around the rubber backing of the button then around the side tubing of the wheelchair; feed the skinny end of the velcro through the slot in the wider end and pull tightly before laying down on its mating surface. Be sure the green LED is pointing up and the cables that come out of each button run towards the back of the wheelchair. The plug cable should hang over the left front side of the seat (as shown below).

*NOTE: If the chair has screw-down seat upholstery, loosen the screws and feed the velcro strap under the metal bar (then retighten screws) to allow for closer positioning of the buttons to the handrims.*

2. Use the provided velcro strips to strap down the button cables to the upholstery, running the right button cable around the back of the seat. Ideal placement of the y-joint in the cable is shown to the right. Be sure the cable does not stick out and will not get caught in the spokes of the wheelchair.

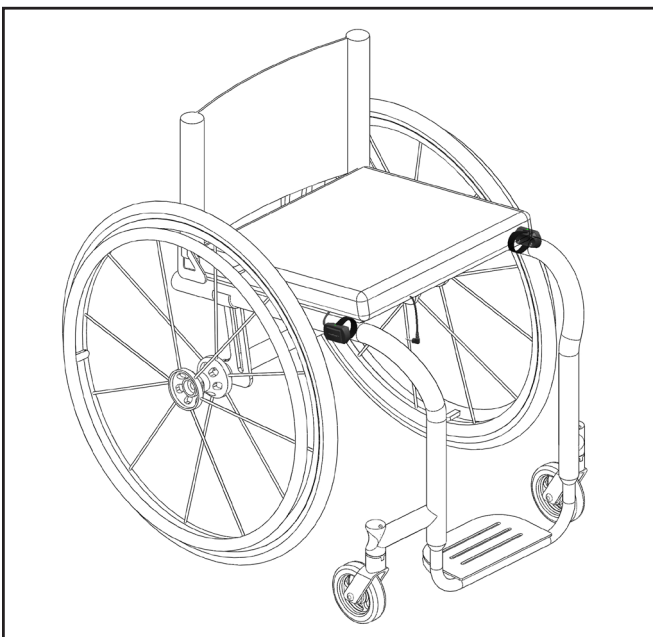
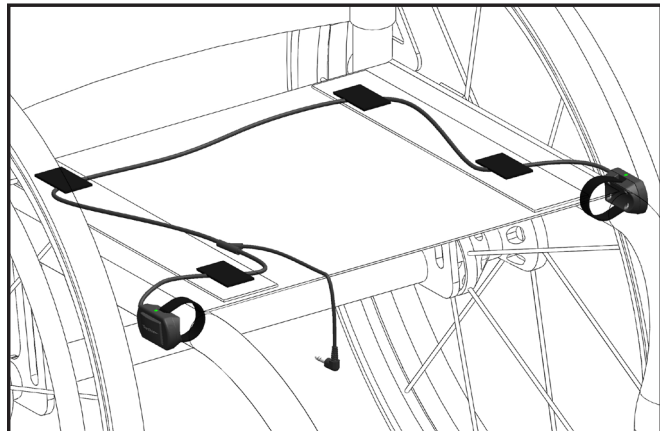

3. Place the cushion over the cable to further secure it. Again, the plug should hang over the left front side of the seat upholstery and come out from under the cushion.

## Drive Unit Attachment and Removal

The SmartDrive drive unit is designed to easily attach to the adaptive clamp so the user can quickly attach/remove whenever desired or necessary. Use of the handle and the drop and lock interaction make attaching the SmartDrive simple for all users.



1. To attach the drive unit to the wheelchair, align the flats in the adaptive clamp with the receiving slots on the front, underside of the unit body [the drive unit will be angled slightly higher than horizontal]. Lower the receiving end of the drive unit over the extrusions of the clamp.

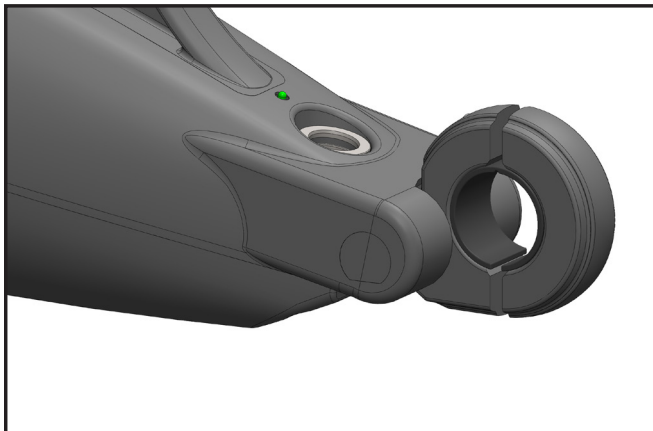

2. Rotate the unit downward to pivotally attach the drive unit to the clamp, and consequently the wheelchair.

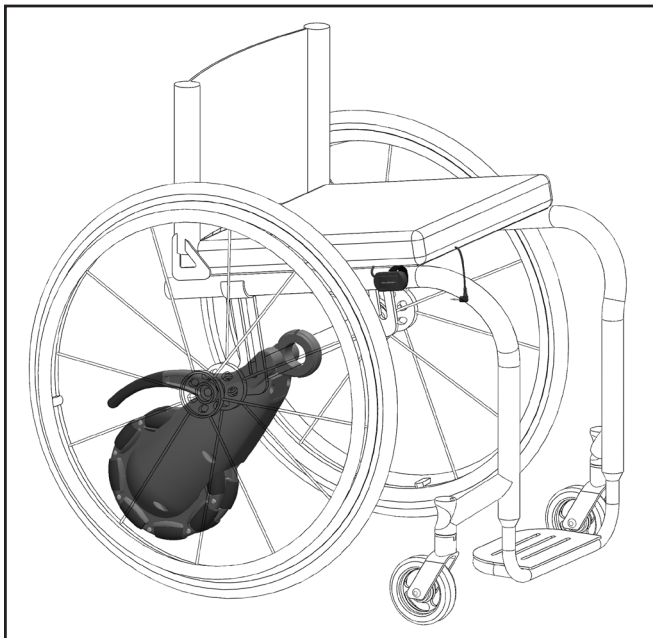

3. Under its own weight, the omni-wheel end of the drive unit rests on the ground between the rear wheels of the wheelchair.

Remove the unit by firmly grasping the handle and performing these steps in reverse order, first rotating upwards then lifting the receiving slots off the adaptive clamp.



**Never attempt to remove the drive unit from the clamp while still seated in the wheelchair. This presents a serious risk of tipping over and injury.**

## Battery Unit Clipping

*NOTE: Refer to the separate directions provided for folding frame wheelchairs, chairs with less than 2 in. under-seat clearance, and other situations (i.e. standing frames) that make attaching the battery unit difficult; then skip to step 4 of this section.*

The Battery Unit is equipped with an oversized clip for attachment to the seat of the wheelchair. The unit is made to latch onto and hang below the upholstered seat. There is a connector holder in the back of the battery unit to aid in cord management when handling the unit, in addition to the handle to assist in carrying/lifting.



1. Pick up the battery unit using the handle presented on the top of the clip.

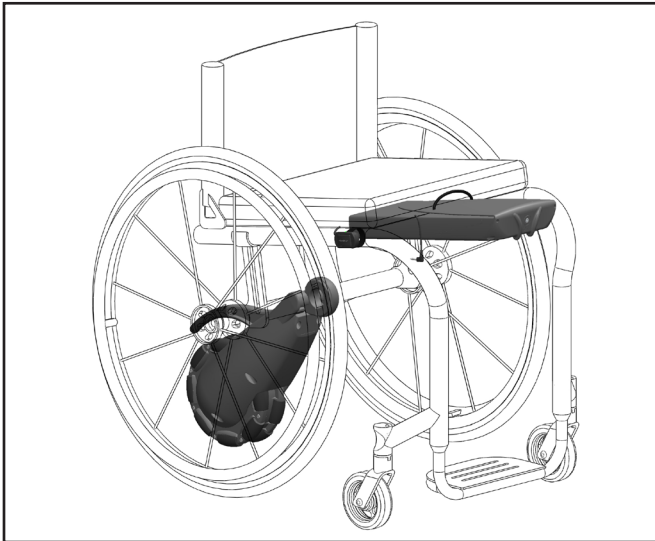

2. Lower the battery unit towards the seat of the wheelchair. Position the upholstery of the seat between the bottom surface of the clip and the top surface of the battery housing. With the Button plug wire to the side, slide the unit back until the front surface of the upholstered seat is making contact with the handle.



3. Slide the battery back as far back as possible by pushing on the front of the unit. Then plug the button plug into the jack on the front of the battery.



**Under-seat clearance must be at least 2 in. for the battery unit to sufficiently fit. Any bulging of the wheelchair upholstery caused by the battery unit has the potential of causing pressure sores. Cease use of the SmartDrive if this condition exists.**

4. Finally, take the connector out of the connector storage holder and plug into the top of the drive unit. There are white alignment arrows on the connector that should face upward for proper connector alignment. The green LED on top of the drive unit will light up and the unit will beep two (2) times when proper connection is made. The connector will automatically lock into the plug when it is fully pushed in.

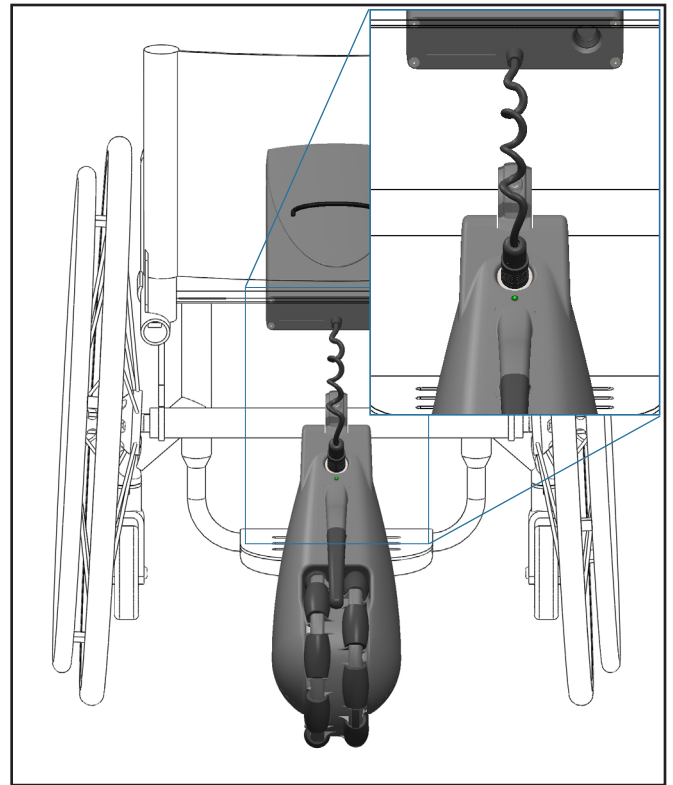

5. To unlock and disconnect the battery from the drive unit, pull up on the outer sleeve of the connector (highlighted in blue in the figure to the right).

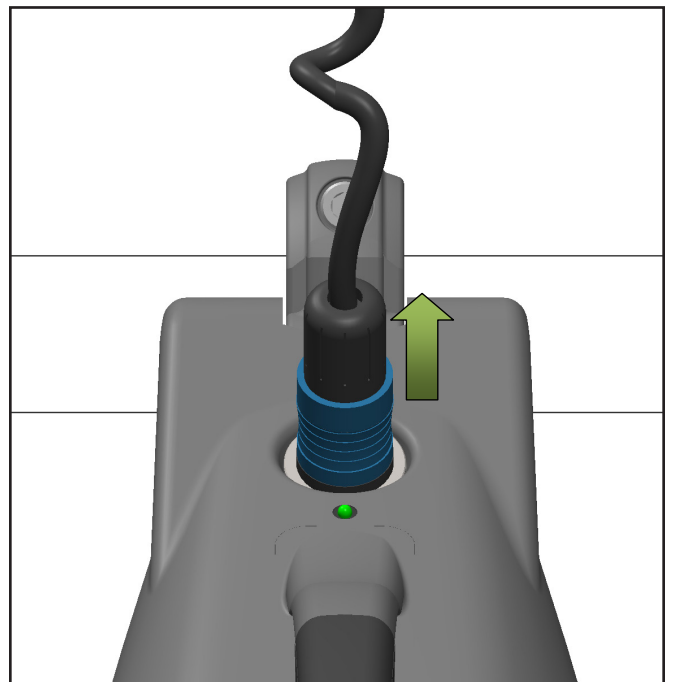

Use extreme caution when attempting to plug or unplug the connector while seated in the wheelchair. This presents a serious risk of tipping over and injury.

Never use the wheelchair as support when clipping/removing the battery unit. Always hold onto a solid structure [i.e. railing, car seat, etc.] when placing the battery unit.

## 3. Operating the SmartDrive

### Power Assist ON/OFF

The user of a SmartDrive equipped wheelchair is able to use the power assist whenever desired or turn the device off and operate their wheelchair as if the SmartDrive was not on their chair.

When a charged battery unit is plugged into the drive unit, the SmartDrive is initially OFF. This state is indicated to the user by the green LED on the top of the buttons not being illuminated and two (2) loud beeps. In this state, no power assist will be able to be used by the wheelchair user. The user may push, turn and brake as they desire with negligible friction or drag from the omni-drive wheel. The wheelchair is a fully functional manual wheelchair with no power assist.

### Switching Between States

When power assist is desired, the user is able to switch the SmartDrive ON by pressing and holding either of the buttons for more than one-half (0.5) second. The SmartDrive defaults to OFF whenever the battery unit is initially connected to the drive unit. By pressing and holding one of the buttons then releasing, the SmartDrive will switch ON and be ready to provide assistive power. An audio indication of one (1) loud beep is produced by the drive unit as an indication to the user that the device is now ON. Also, the green LED on the buttons will be illuminated when the SmartDrive is ON. One can switch it back OFF by pressing and holding for more than one-half (0.5) second then releasing either button, in which the state change is indicated by two (2) loud audio beeps from the drive unit, and the green LED on each of the buttons will turn off. The motor must not be driving to turn the SmartDrive OFF.

### Power Assist State

The SmartDrive is equipped with two modes of power assist to aid the user in most situations encountered on a daily basis.

The first is Indoor Mode, and the second is called Outdoor Mode. This second mode is ideal for special times when easy power activation is needed, such as on inclines and thick carpet, and when environmental conditions are more diverse. Switching between modes is done by pressing and quickly releasing either of the buttons with the power assist state ON and the motor not activated. This switch is indicated by one (1) loud beep and button LED change (either **solid** or **blinking**).

### Indoor Mode

When the power assist is turned ON, the SmartDrive is initially in Indoor Mode. This state is indicated by **solid** illumination of the green LED on the top of each button. In this mode, the SmartDrive is able to recognize when you have performed a push on the wheelchair. In turn, the device activates the omni-drive wheel, and an assistive drive power is provided, propelling you at a speed equal to that which was attained by the push. The SmartDrive is able to recognize each individual's push, so no alterations to one's propulsion technique is needed. This is ideal for everyday indoor use as it reduces the number of pushes that you have to perform.

The SmartDrive is designed to continue to assist the user until braking is sensed, the device is turned off by pressing a button [both described in section **Braking**] or until another, faster push is performed. In this case, the SmartDrive will speed up and begin to drive the user at this faster speed attained when the user pushed harder.

If any malfunctions or push detection/braking/push-button issues are experienced with the SmartDrive, cease use of the device and contact Max Mobility for assistance.



**The SmartDrive is able to recognize all types of pushes. Do not alter the way that you push for this could lead to injuries in the future.**

**In addition to braking the handrims in Indoor Mode, the push activated power assist can always be stopped by quickly pressing and releasing the push-button.**

**Care should be taken when taking the SmartDrive down an incline. Consider switching the device OFF when descending down a slope.**

**The acceleration of the SmartDrive could cause the wheelchair to tip-over backwards, causing injury. It is recommended that the user lean slightly forward to prevent this tipping.**



## Braking

In addition to recognizing pushes, the SmartDrive is also able to sense when one is braking. When the user slows the wheelchair down with pinching of the handrims, the drive unit senses the braking and deactivates the power assist. If a push is performed after, then the power assist will turn back on and drive the user.

In addition to braking, a user who chooses to stop the power assist at any time is able to do so by pressing either of the buttons. The device will continue to be in its current mode if the power assist is stopped by pressing a button.

If any malfunctions or push detection/braking/push-button issues are experienced with the SmartDrive, cease use of the device and contact Max Mobility for assistance.



**Regular braking technique should be practiced when using the SmartDrive. In certain situations, especially at higher speeds, harder braking will be required to turn off the power assist.**

**In addition to braking, the push activated power assist can ALWAYS be stopped by pressing either of the buttons.**

**Always be aware of which mode you are in by looking at the green LED's on the top of the button.**

## Outdoor Mode

Outdoor Mode is the second mode. Switched to this mode by pressing and quickly releasing either button when the SmartDrive is in Indoor mode and the motor is not driving [the drive unit do one (1) loud beep]. Also the green LED on the buttons will continually **blink** while you are in Outdoor Mode. Regular check which mode you are in by looking at these LED's.

In this mode, there is Easy Start that allows the user to easily activate the motor and reach one of the five speed steps that are pre-programmed. The five speed steps that can be driven at are 1.5 mph, 2.5 mph, 3.5 mph, 4.5 mph and maximum speed which is shown on the **Specification Sheet** [see page I]. The SmartDrive will sense which step your push was closest to reaching and activate the motor to drive at that step's speed. A faster speed step can be reached while the motor is powering at the lower speed by performing another harder push.

This Easy Start activation in Outdoor Mode is especially useful when on a steep hill, incline, ramp, etc. where it might be difficult to reach a sufficient speed for Indoor Mode power activation.

In Outdoor Mode, the power assist is **ONLY** able to be deactivated by pressing one of the buttons. Once a push is performed and the motor is activated, position your hands over your handrims and buttons to be prepared to turn off the motor when braking/deactivated power is needed.

Anytime that the power assist is stopped by a button press in Outdoor Mode, automatic rollback resistance lasting (3) seconds will be provided to prevent the wheelchair and the user from rolling backwards, which is especially helpful on hills and inclines. Whenever the rollback resistance is not activated, the SmartDrive will roll backwards freely.

The SmartDrive will continue to be in Outdoor Mode after the power assist is stopped by a button press. Another performed push will reactivate the motor, again **ONLY** to be deactivated by a button press. To get back into Indoor Mode, with the motor not activated, press and quickly release one of the buttons; the drive unit will produce one (1) loud beep and the green LED's on the button will turn to **solid** illumination. Switch to power assist OFF state by pressing and holding one of the buttons for more than one-half (0.5) seconds while the motor is not activated. This switch will be indicated by two (2) loud beeps and the LED's on the buttons will turn off.



**Outdoor Mode operation of the SmartDrive is not intended to be used indoors. Use caution when using this mode of operation, especially indoors.**

**The buttons should be positioned in close proximity to the handrims to allow for easy pressing access.**

**The acceleration of the SmartDrive could cause the wheelchair to tip-over backwards, causing injury. It is recommended that the user lean slightly forward to prevent this tipping.**

**Serious care should be taken on all hills, inclines, ramps, etc.**

(Continued on next page)





**The rollback resistance may not be able to prevent the slow rolling back on especially steep slopes and/or very heavy wheelchair users.**

**Rollback resistance is not a parking brake. Be sure to secure your wheelchair with brakes if stopping on a slope is desired.**

## Operating Conditions

The SmartDrive is designed for typical operating conditions encountered by a manual wheelchair user on a daily basis. Max Mobility recommends restricting the use of this device to indoor and light outdoor use. All operating conditions set forth by one's wheelchair manufacturer should always be heeded, in addition to the avoidance of the following:

- Long carpet
- Slick or wet tile
- Loose dirt or gravel
- Standing water
- Icy surfaces
- Rough terrain
- Extreme slopes
- Heavy rain or snow

The total weight of the SmartDrive assembly is 19.8 lbs. This weight should be included in calculating the on-board weight of the wheelchair. The maximum allowable on-board weight outlined by one's wheelchair manufacturer should never be exceeded with the addition of the SmartDrive.

If any part of the SmartDrive is accidentally gotten wet, the user should cease usage and allow 12 hours for it to air dry before attempting to use again.

The operating temperatures of the SmartDrive are -25 °C and 50 °C.

If any malfunctions or issues are experienced with the SmartDrive, cease use of the device and contact Max Mobility for assistance.

## 4. Battery



**Although the battery on the SmartDrive is very small and compact, it can store a large amount of power. Faulty handling or storage can damage the equipment, and in some cases result in shocking, burns, or fire.**

The battery unit houses the rechargeable Lithium Iron Phosphate batteries used to power the SmartDrive. The newest in Lithium-Ion technology, these batteries offer a significantly longer cycle life and faster charging rate than standard lithium ion cells.

The green LED on the top of the buttons is used to indicate when the battery charge level is low. The green LED of the buttons will provide (3) quick flashes whenever the power assist is OFF [not in Indoor or Outdoor Modes] and the battery level has dropped below 30% capacity. Charging of the battery should be done as soon as possible to avoid running completely out.

It is encouraged to charge your battery every night to avoid running out of charge during daily use. The life of the battery will not be deteriorated by charging when it is partially drained.

Avoid getting the battery unit wet, for this can cause a short. It is also recommended to always place the connector in the connector holder on the back of the battery unit whenever it is not plugged into the drive unit.

Long-term storage of the battery [more than 3 months] reduces its capacity through spontaneous discharge. Charge the battery to at least 30% before you store it long-term, and avoid storing the unit where the temperature is too high or with high humidity.



**Always store and charge the battery in a cool, dry area. Hot and damp environments can damage or short the unit, requiring a costly replacement.**

**Avoid dropping of the battery unit.**

**Never get the battery unit wet. This can cause a short or permanently damage the battery unit.**

**Only use the provided charger to recharge the battery of the SmartDrive. Other chargers may damage your unit, or cause a fire.**



Do not throw away the battery unit. Please properly dispose of the battery unit by recycling at the end of its life or send it back to Max Mobility.

**Li-ion**



## 5. Maintenance

### Cleaning

Cleaning of the SmartDrive can be done by wiping all of the parts down with a damp wash rag. This should be done at least once a month, or as needed.

### Roller Lubricating or Replacement

The omni-drive wheel contains 16 rubber rollers that may wear down, depending on driving conditions, after extensive use. These rollers are able to be replaced. Also, in snowy climates, salt may cause corrosion to the bearings on these rollers and effect their performance. Spraying lubrication on these bearings will increase their usable lives. Contact your mobility equipment dealer or Max Mobility for information on replacing/maintaining the rollers on your SmartDrive unit.

### Other Maintenance

Contact Max Mobility or your mobility equipment dealer for any other maintenance or replacement that the device might need.

## 6. Warranty

Max Mobility offers a 2 year warranty against manufacturing defects. Max Mobility's obligation under this warranty shall be limited to repairing or providing replacement of part(s), which are found to be defective. Any part(s) of the system replaced by us at our discretion shall be with a functionally operative part.

This warranty may be voided if: 1) the product is not used according to instructions given in this instruction manual, 2) defects were caused by improper use as determined by the company personnel, 3) modification or alteration of any nature is made in the electrical circuitry or physical construction, or 4) defects are due to cause beyond control like lightning, abnormal voltage or while in transit at the purchaser's place of business.

Max Mobility is not responsible for any damage to one's wheelchair caused by the attachment or operation of the SmartDrive.

### Manufacturer's Contact Information

Manufacturer: Max Mobility, LLC  
Address: 5425 Crossings Blvd.  
Antioch, TN 37013  
USA  
Phone: (800) 637-2980  
Fax: (888) 411-9027  
Website: [www.max-mobility.com](http://www.max-mobility.com)  
Email: [support@max-mobility.com](mailto:support@max-mobility.com)

## 7. European Commission (EC) Authorized Representative



Advena Ltd.  
Pure Offices  
Plato Close  
Warwick CV34 6WE  
United Kingdom

5425 crossings boulevard, nashville, tn 37013 usa • p: 800.637.2980 • f: 888.411.9027 • [www.max-mobility.com](http://www.max-mobility.com)